

B

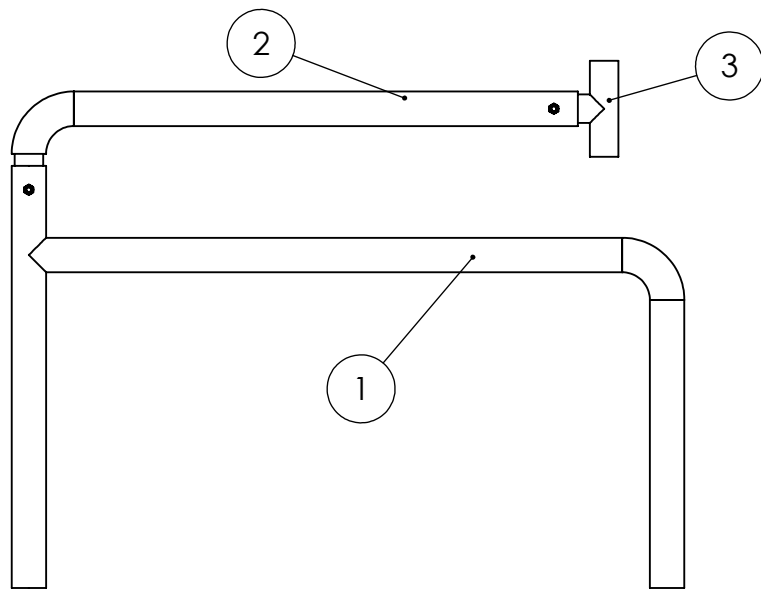

1

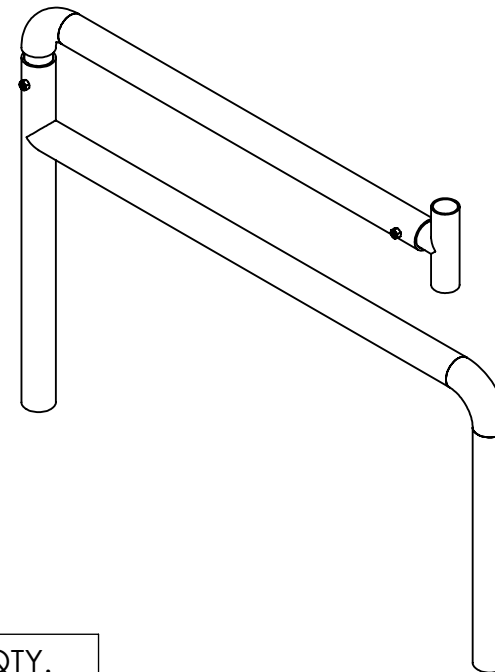

B

ITEM NO.	PART NUMBER	DESCRIPTION	QTY.
1	Base		1
2	L Shaped Vertical Slide		1
3	Horizontal Top Slide		1

A

A

PROPRIETARY AND CONFIDENTIAL
 THE INFORMATION CONTAINED IN THIS DRAWING IS THE SOLE PROPERTY OF <INSERT COMPANY NAME HERE>. ANY REPRODUCTION IN PART OR AS A WHOLE WITHOUT THE WRITTEN PERMISSION OF <INSERT COMPANY NAME HERE> IS PROHIBITED.

		UNLESS OTHERWISE SPECIFIED:		NAME	DATE
		DIMENSIONS ARE IN INCHES	DRAWN		
		TOLERANCES:	CHECKED		
		FRACTIONAL \pm	ENG APPR.		
		ANGULAR: MACH \pm BEND \pm	MFG APPR.		
		TWO PLACE DECIMAL \pm	Q.A.		
		THREE PLACE DECIMAL \pm	COMMENTS:		
		INTERPRET GEOMETRIC TOLERANCING PER:			
		MATERIAL			
NEXT ASSY	USED ON	FINISH			
APPLICATION		DO NOT SCALE DRAWING			

TITLE:

Assembly View Hoosier Pole

SIZE

A

DWG. NO.

Hoosier Pole

REV

SCALE: 1:12 WEIGHT:

SHEET 1 OF 4

2

1

2

1

B

B

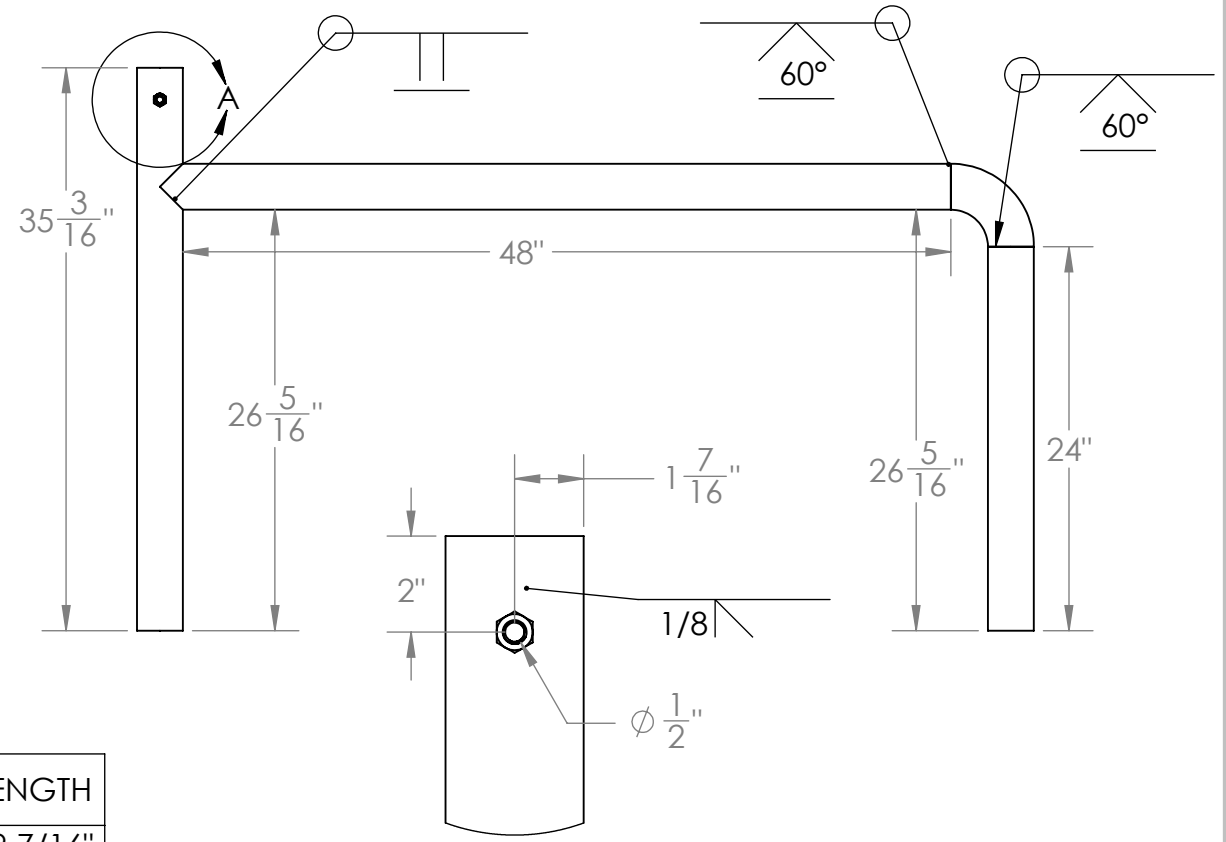
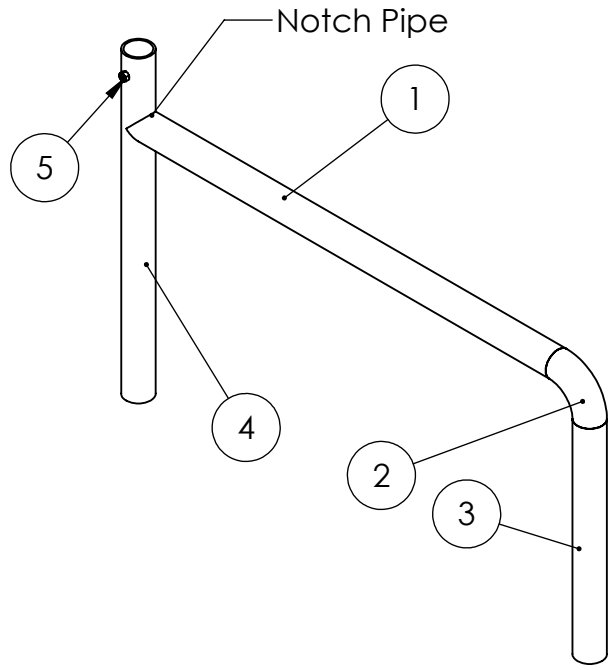

DETAIL A
SCALE 1 : 4

ITEM NO.	QTY.	DESCRIPTION	LENGTH
1	1	PIPE 2.5 SCH 40	49 7/16"
2	1	PIPE 2.5 SCH 40	5.89
3	1	PIPE 2.5 SCH 40	24"
4	1	PIPE 2.5 SCH 40	35 3/16"
5	1	1/2" Nut	

A

A

PROPRIETARY AND CONFIDENTIAL
THE INFORMATION CONTAINED IN THIS DRAWING IS THE SOLE PROPERTY OF <INSERT COMPANY NAME HERE>. ANY REPRODUCTION IN PART OR AS A WHOLE WITHOUT THE WRITTEN PERMISSION OF <INSERT COMPANY NAME HERE> IS PROHIBITED.

		UNLESS OTHERWISE SPECIFIED:		NAME	DATE
		DIMENSIONS ARE IN INCHES		DRAWN	
		TOLERANCES:		CHECKED	
		FRACTIONAL ±		ENG APPR.	
		ANGULAR: MACH ± BEND ±		MFG APPR.	
		TWO PLACE DECIMAL ±		Q.A.	
		THREE PLACE DECIMAL ±		COMMENTS:	
		INTERPRET GEOMETRIC TOLERANCING PER:			
		MATERIAL			
		FINISH			
NEXT ASSY	USED ON				
APPLICATION		DO NOT SCALE DRAWING			

TITLE:		
<h1>Base</h1>		
SIZE	DWG. NO.	REV
A	Hoosier Pole	
SCALE: 1:12	WEIGHT:	SHEET 2 OF 4

2

1

2 1

B

B

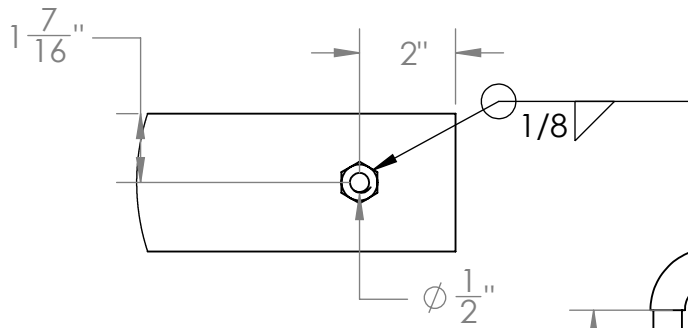

DETAIL B
SCALE 1 : 4

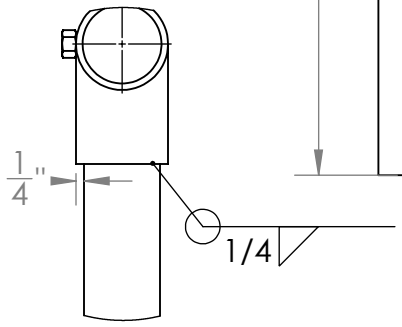
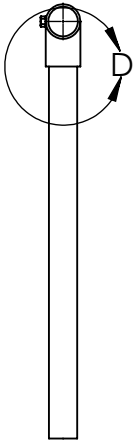
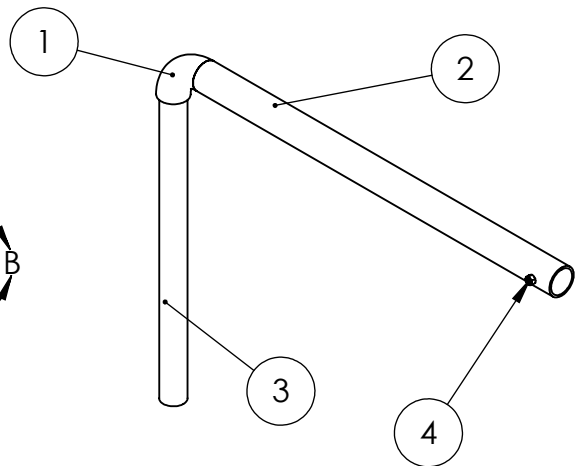
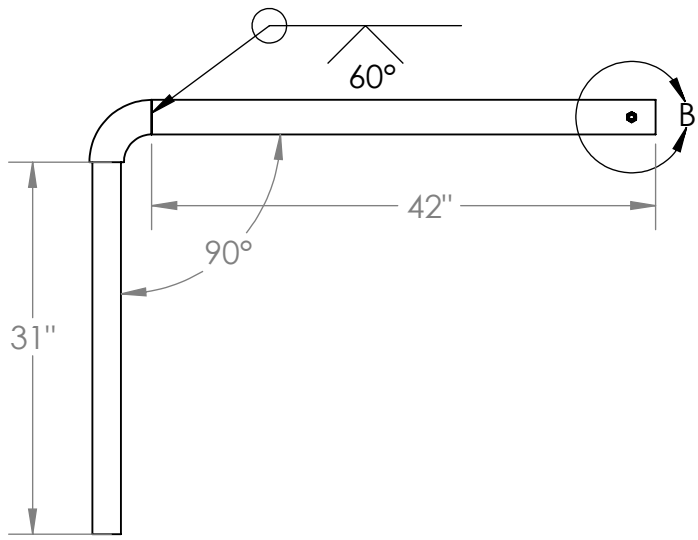

DETAIL D
SCALE 1 : 6

ITEM NO.	QTY.	DESCRIPTION	LENGTH
1	1	PIPE 2.5 SCH 40	5.89
2	1	PIPE 2.5 SCH 40	42"
3	1	PIPE 2 SCH 40	31"
4	1	1/2" Nut	

A

A

PROPRIETARY AND CONFIDENTIAL
THE INFORMATION CONTAINED IN THIS DRAWING IS THE SOLE PROPERTY OF <INSERT COMPANY NAME HERE>. ANY REPRODUCTION IN PART OR AS A WHOLE WITHOUT THE WRITTEN PERMISSION OF <INSERT COMPANY NAME HERE> IS PROHIBITED.

		UNLESS OTHERWISE SPECIFIED:		NAME	DATE
		DIMENSIONS ARE IN INCHES	DRAWN		
		TOLERANCES:	CHECKED		
		FRACTIONAL ±	ENG APPR.		
		ANGULAR: MACH ± BEND ±	MFG APPR.		
		TWO PLACE DECIMAL ±	Q.A.		
		THREE PLACE DECIMAL ±	COMMENTS:		
		INTERPRET GEOMETRIC TOLERANCING PER:			
		MATERIAL			
NEXT ASSY	USED ON	FINISH			
	APPLICATION	DO NOT SCALE DRAWING			

TITLE: Vertical Slide		
SIZE A	DWG. NO. Hoosier Pole	REV
SCALE: 1:12	WEIGHT:	SHEET 3 OF 4

2 1

2

1

B

B

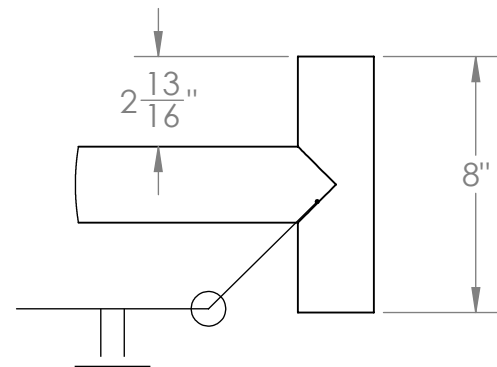
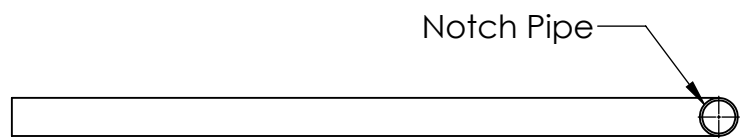
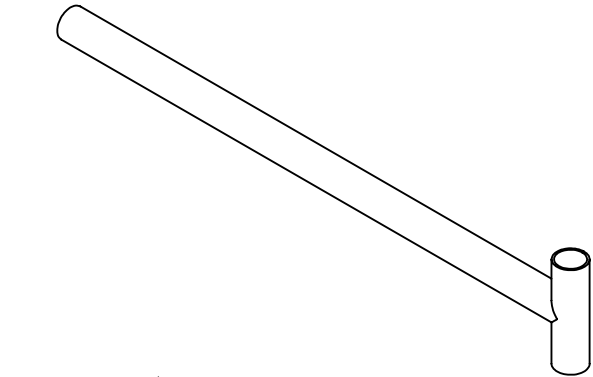
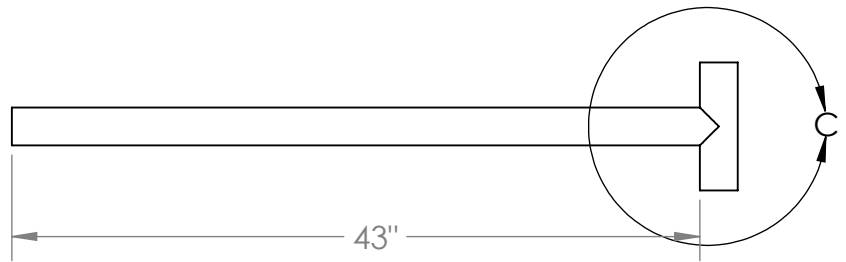

DETAIL C
SCALE 1 : 6

ITEM NO.	QTY.	DESCRIPTION	LENGTH
1	1	PIPE 2 SCH 40	44 3/16"
2	1	PIPE 2 SCH 40	8"

A

A

PROPRIETARY AND CONFIDENTIAL
 THE INFORMATION CONTAINED IN THIS DRAWING IS THE SOLE PROPERTY OF <INSERT COMPANY NAME HERE>. ANY REPRODUCTION IN PART OR AS A WHOLE WITHOUT THE WRITTEN PERMISSION OF <INSERT COMPANY NAME HERE> IS PROHIBITED.

		UNLESS OTHERWISE SPECIFIED:
		DIMENSIONS ARE IN INCHES TOLERANCES: FRACTIONAL ± ANGULAR: MACH ± BEND ± TWO PLACE DECIMAL ± THREE PLACE DECIMAL ±
		INTERPRET GEOMETRIC TOLERANCING PER:
		MATERIAL
		FINISH
NEXT ASSY	USED ON	
APPLICATION		DO NOT SCALE DRAWING

	NAME	DATE
DRAWN		
CHECKED		
ENG APPR.		
MFG APPR.		
Q.A.		
COMMENTS:		

TITLE:
Horizonatal Slide

SIZE	DWG. NO.	REV
A	Hoosier Pole	
SCALE: 1:8	WEIGHT:	SHEET 4 OF 4

2

1